

ORDINANCE NO. _____

AN ORDINANCE OF RADNOR TOWNSHIP, DELAWARE COUNTY, PENNSYLVANIA, AMENDING CHAPTER 255, SUBDIVISION AND LAND DEVELOPMENT, OF THE CODE OF THE TOWNSHIP OF RADNOR, CREATING A NEW ARTICLE X, GARRETT HILL ZONING DISTRICT; ESTABLISHING NEW TREE DESIGN STANDARDS, STREETLIGHT AND PARKING LIGHT STANDARDS, SIDEWALK AND CURB DESIGN STANDARDS, PARKING STANDARDS, CROSSWALK STANDARDS, SIGN STANDARDS AND SPECIFIC SITE AMENITY STANDARDS FOR ALL NEW OR REDEVELOPED PROPERTIES IN THE GARRETT HILL ZONING DISTRICT.

WHEREAS, the Radnor Township Board of Commissioners adopted the Garrett Hill Master Plan on July 21, 2008, establishing policy changes for the Garrett Hill area, including amendments to preserve existing development patterns while establishing a community vision for the Garrett Hill area; and

WHEREAS, the Garrett Hill Master Plan is a continuation of the goals and recommendations from the Radnor Township 2003 Comprehensive Land Use Plan; and

WHEREAS, the Garrett Hill Master Plan recommends the establishment of multiple sub-districts within the Garrett Hill area in order to encourage reinvestment and the continuation of the Garrett Hill District as a historic village community; and

WHEREAS, Section 503(2) of the Pennsylvania Municipalities Planning Code, 53 P.S. 10503(2), permits provisions insuring that subdivisions or land developments conform to the Township's Comprehensive Plans; and

WHEREAS, Sections 503(3) and (5) of the Pennsylvania Municipalities Planning Code, 53 P.S. 10503(3) and (5), permit the Township to enact provisions governing the design of streets, walkways, curbs, and other transportation improvements; and provisions for encouraging and promoting flexibility, economy and ingenuity in the layout and design of subdivisions and land developments, and provisions which encourage practices in accordance with modern principles of site planning and development.

NOW, THEREFORE, be it **ORDAINED** and **ENACTED** that the Board of Commissioners does hereby amend Chapter 255, Subdivision and Land Development, of the Radnor Code of Ordinances as follows:

Section 1.

§255-6. Definitions and word usage is hereby amended to add the following new definition:

SITE AMENITY – A public space improvement, including but not limited to landscaping, sidewalks, street lighting and parking.

Section 2.

§255-88. Legal basis.

A new Article X creating provisions for the “Garrett Hill Zoning District” within Chapter 255 (SUBDIVISION) of the Township Code is enabled through provisions of the Pennsylvania Municipalities Code, PL 805, No. 247, as reenacted and amended. .

§255-89. Purpose; intent of regulations.

Article X of the Zoning Code is hereby enacted to provide and manage opportunities for development and redevelopment within the “Garrett Hill Zoning District” (hereinafter GHZD) as set forth in the “Garrett Hill Master Plan” adopted by the Board of Commissioners on July 21, 2008, and revised on July 20, 2009. These regulations are intended to provide for enhanced vibrancy through building, site, and streetscape design.

§255-90. Designation of district boundaries.

The GHZD shall be the boundaries designated within the Garrett Hill Zoning District Map.

§255-91. Conflict with other code sections.

The definitions and regulations set forth in this article shall apply to the GHZD.

Wherever there is a conflict or inconsistency between these GHZD regulations and other definitions and regulations of Chapter 255, those regulations set forth in this article shall govern development and redevelopment within the GHZD.

§255-92. Site amenity requirements.

A. Upon demolition of a principal building or structure, site amenities shall be provided and installed by the applicant where required by this Chapter.

B. The amenities shall be installed by the applicant or, by agreement between the Township and applicant, the cost for such installation shall be escrowed in a Township fund or a Township-approved trust fund dedicated to GHZD improvements, to be held until applied to the installation of site amenities on the property for which the installation was deferred. The applicant shall not be required to spend more than 5% of the cost of improvements for the site amenities.

C. The maintenance of these amenities shall be provided by the property owner where applicable. Each application will be reviewed individually. Required amenities, or any deviation there from, shall be at the discretion of the Township.

§255-93. Tree design standards.

Street trees shall be installed and maintained as follows:

A. Street trees, 2-1/2 to 3 inches in caliper, shall be planted along both sides of Conestoga Road at an interval of 25 feet on center, but they shall not block visibility of existing

store windows. In spacing trees, consideration shall be made for driveways, streetlights, utility poles, underground utilities, traffic light poles and other obstructions, the existing streetscape, as well as future placement of trees in front of adjacent properties. (See Figure 1).

- B. Street trees shall be deep rooted and stress tolerant and shall be of the following species or as approved by the Shade Tree Commission:

Acer buergerianum – Trident Maple
 Acer Japonicum – Fullmoon Maple
 Acer palmatum – Japanese Maple
 Acer trifolium – Three-flower Maple
 Acer truncatum – Shantung Maple
 Carpinus betulus ‘fastigiata’ -
 American Hornbeam
 Crataegus viridis ‘Winter King’ -
 Winter King Hawthorn
 Maackia amurensis – Amur Maackia
 Magnolia virginiana [single stem] -
 Sweet Bay Magnolia
 Malus ‘Donald Wyman’ - flowering
 crabapple selection
 Prunus x incam ‘Okame’ - Okame
 Cherry
 Sorbus alnifolia – Korean mountain
 Ash
 Syringa reticulata – Japanese Tree
 Lilac

§255-94. Streetlight, parking lot and exterior light standards.

- A. Streetlights shall be installed as follows:

- (1) Fixtures shall be 12 feet high and shall meet Illuminating Engineering Society of North America (IESNA) “cutoff” or “full-cutoff” criteria.

- (2) Street lights shall be spaced a maximum of 40 feet apart on each side of the street in an offset alternating arrangement along both sides of street.

- (3) Street light poles and fixtures shall be of compatible design throughout the GHZD, unifying the Route 100 station area and all GHZD Districts.

- B. Parking lot lights shall be installed as follows:

- (1) Full cutoff light fixtures shall be used to direct light downwards. For the GH-N, GH-GA, GH-CR, GH-OS Districts, fixture height shall not be higher than 12 feet. Fixture height shall be limited to 20 feet in the GH-BC District.

- (2) Shields shall be used to deflect light away from adjacent properties so that no direct light from the filament, bulb or lens is visible from outside the property.

- C. Exterior lights attached to buildings:

- (1) External lighting shall be restricted to that which is necessary for minimum safety and security levels. Light standards shall be low profile and shall have a sharp cut-off shield and directed downward to reduce dispersal of ambient light to the night sky. Sodium vapor lights shall not be allowed.

§255-95. Sidewalk design standards.

Sidewalks shall be provided as follows:

- A. Sidewalks shall have a minimum width of:

- (1) 6 feet on Conestoga Road.
- (2) 4 feet on Garrett Avenue.
- B. Whenever any perpendicular or angled parking abuts a sidewalk, wheel stops shall be installed to prevent car overhang.
- C. Sidewalks shall be made of concrete or brick.
- D. Concrete shall have no exposed aggregate or color additive.
- E. On Conestoga Road, concrete sidewalks shall be designed to be consistent with **Figure 2** and to match adjoining properties as follows:
 - (1) Have 24 inch x 24 inch squares.
 - (2) Have a 24 inch brick herringbone border with a 6 inch curb.
- F. On Garrett Avenue, concrete sidewalks shall:
 - (1) Have 36 inch x 36 inch squares.
 - (2) Have a 12" herringbone border with a 6 inch curb (**See Figure 3**).

§255-96. Curb standards.

Curbs shall be installed and maintained as follows:

- A. Curbs shall be provided along all streets and access drives.
- B. Curbs shall be of the vertical concrete type with a 6 inch reveal.
- C. Curbs shall comply with Article 255-51 of the Township Code.

- D. Curbs shall be made to provide barrier-free access and to accommodate pedestrians with disabilities, in accordance with ADA standards.
- E. All low points along curbs shall be adequately drained to prevent flooding and ponding of water.

§255-97. Curb cut design standards.

- A. New driveways shall be discouraged.
- B. Existing driveways shall be narrowed to the maximum extent possible.
- C. Two-way driveways shall not be required to meet the minimum widths standards otherwise required in this Chapter. This provision shall not apply to GH-BC.
- D. Existing curb cuts that are no longer needed shall be sealed-off and replaced with 6 inch curbing and sidewalks.
- E. Whenever there is an existing curb cut, the sidewalk material (concrete, brick, etc.) and design shall be extended to promote pedestrian continuity along the sidewalk. A terra-cotta colored brick pattern that is stamped into newly laid concrete to match the adjoining sidewalk in color, texture and pattern is also acceptable.
- F. Shared driveways through agreements between adjoining property owners are hereby encouraged and shall be subject to Township approval.

§255-98. Ingress and egress.

- A. Existing curb cuts may be modified, or shared with adjacent property owners, provided there is no increase in the number of existing curb cuts.
- B. Wherever possible, ingress and egress between various properties shall be shared in an attempt to minimize curb cuts. The Township encourages adjacent landowners to enter into agreements providing access easements to accomplish this goal.

§255-99. Parking standards.

Parking shall be as follows:

- A. On-street parking shall be provided to the maximum extent possible and as follows:

- (1) Curbside, parallel on-street parking spaces shall be at least 8 feet in width and 22 feet in length. **(See Figure 4).**
- (2) Curbside perpendicular parking spaces shall be at least 9.5 feet in width and 20 feet in depth and shall have a 4.5-foot backup buffer between each row of spaces and the travel lane. **(See Figure 5).**

- B. Off-street parking shall be located in the front, side or rear yards and shall meet the following standards:

- (1) Front yard parking shall be limited to curbside perpendicular parking.
- (2) Front yard perpendicular parking spaces shall meet the following standards:

- (a) Spaces shall be at least 9.5 feet in width and 20 feet in depth.

- (b) A 4.5-foot backup buffer shall be provided between each row of spaces and the travel lane. **(See Figure 5).**

- (3) Side and rear yard parking spaces shall be at least 9 feet in width and 18 feet in depth.

- (4) All side and rear commercial parking areas shall be buffered from views from adjacent residential properties.

- (5) The buffer shall be an opaque evergreen vegetated buffer at least 6 feet in height and 3 feet in depth at the time of planting and shall be maintained by the property owner.

- (6) If fencing is incorporated in any parking lot, it shall be designed so that not more than 25% of fence permits through-views. Fencing shall be between 4-6 feet in height.

- (7) Buffer screen shall not be required should existing planting, topography or man-made structures remaining on the property be deemed acceptable for screening purposes by the Township.

- C. Parking surfaces shall be installed and maintained and shall be asphalt, concrete or approved equal. Permeable pavements that meet Pennsylvania Stormwater Manage-

ment Manual porous pavement specification are encouraged.

§255-100. Crosswalk standards.

Crosswalks at street intersections shall be consistent with the “Master Plan” and as follows:

- A. Crosswalks shall be provided at all street intersections.
- B. Crosswalks shall be from 6-12 feet in width.
- C. Crosswalks shall either be painted or stamped.
 - (1) At a minimum the design shall mark the crosswalks with broad painted stripes that are parallel to the cartway and not less than 6 feet in length, 12 inches in width and not more than 24 inches apart.
 - (2) Colored and textured pavement shall be used to enhance the aesthetics of the crosswalks at gateway locations and the Conestoga Road/Garrett Avenue intersection. A terra cotta colored, brick pattern that is stamped into newly laid concrete with at least an 8 inch uncolored concrete border shall be encouraged.
- D. Crosswalks shall otherwise comply with §255-39.

§255-101. Trash receptacle standards.

Waste and recycling receptacles shall be provided consistent with **Figure 7** and the following:

- A. Victor Stanley, Model S-42 Ironsite in a color to match the streetlights, or

approved equal shall be installed, anchored, and serviced.

- B. Waste and recycling receptacles may be located at each corner and at the discretion of the Township at a minimum of every 200 feet of sidewalk length along Conestoga Road in the GHZD.
- C. The Township shall be responsible for emptying and maintaining these receptacles.

§255-102. Wayfinding standards.

- A. Wayfinding signage to aid in finding locations for parking and the Route 100 station shall be installed and maintained by the Township.
- B. Design and location of wayfinding standards shall be subject to Design Review Board approval.

§255-103. Site amenity standards.

The following standards shall apply to all new or redeveloped properties in the GHZD:

- A. Conestoga Road (Without front yard parking) (**See Figure 8**).
 - (1) A 6 inch curb.
 - (2) A 24 inch brick border at curb line .
 - (3) Minimum concrete sidewalk width of 4 feet.
 - (4) A 3.5 foot planted buffer.
 - (5) Lights within 24 inches of the curb line .
 - (6) Street trees centered in the 24 inch brick border; trees shall be

in grates manufactured by Neenah Foundry or an equal approved by the Zoning Officer.

- (7) Bulbout plus stamped concrete paving to match brick borders in color, texture and size for properties at corner locations.
- (8) Planters are encouraged against the building front or along the curb line.

B. Conestoga Road (Perpendicular parking in the front yard) (See Figure 6).

- (1) Parking plus 6 inch curb, 24 inch brick border and 4 foot concrete sidewalk.
- (2) Concrete paving to building.
- (3) Lights within 24 inches of the curb line.
- (4) Street trees centered in the 24 inch brick border; trees shall be in grates manufactured by Neenah Foundry or an equal approved by the Zoning Officer.
- (5) Bulbout plus stamped concrete paving to match brick borders in color, texture and size for properties at corner locations.
- (6) Planters are encouraged against the building front or along the curb line.

C. On a local or collector street in the Conestoga Road District, when perpendicular parking is constructed:

- (1) Parking plus 6 inch curb, 24 inch brick border and 4 foot sidewalk.
- (2) Concrete paving to building.
- (3) Bulbout stamped concrete paving to match brick borders in color texture and size for properties at corner locations.
- (4) Planters are encouraged against the building front or along the curb line.

D. Garrett Avenue in the Garrett Avenue Mixed-Use District (See Figure 9).

- (1) Lights in bulbouts according to the Garrett Hill Master Plan design shall be required.
- (2) The installation of light fixtures in the front yard is hereby encouraged. Fixtures shall be 6 feet high and meet Illuminating Engineering Society of North America “cutoff” or “full-cutoff” criteria.

E. Garrett Avenue in the Garrett Avenue Neighborhood District:

- (1) Lights in bulbouts according to the Garrett Hill Master Plan design are hereby encouraged.
- (2) The installation of light fixtures in the front yard shall be encouraged. Fixtures shall be 6 feet high and meet Illuminating Engineering Society of North America “cutoff” or “full-cutoff” criteria.

Figure 1

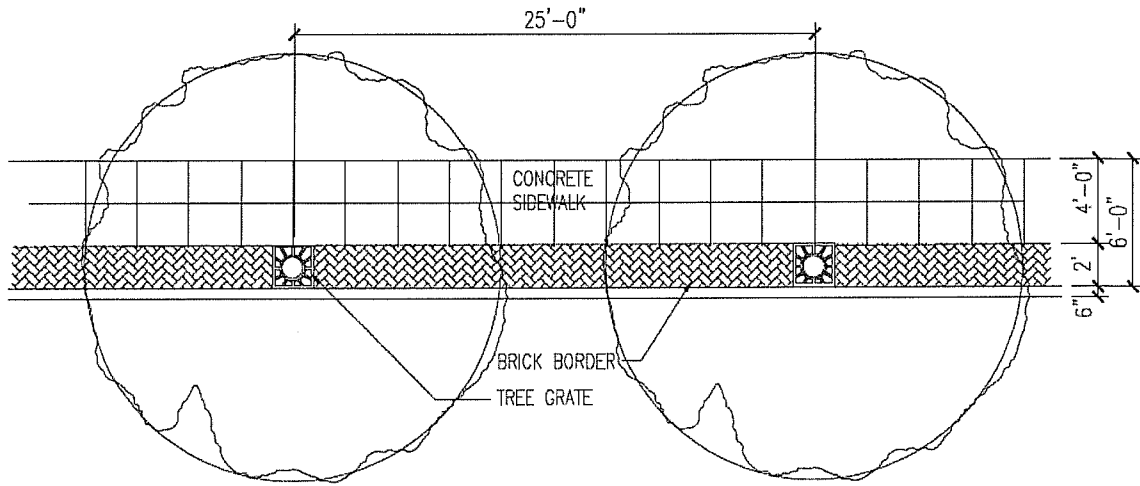

Conestoga Road (without front yard parking)

Figure 2: Conestoga Road

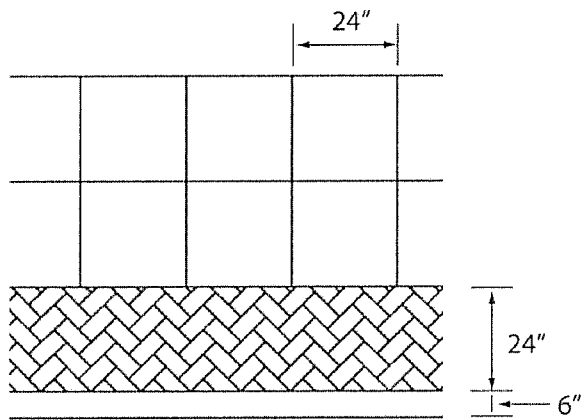

Figure 3: Garrett Avenue

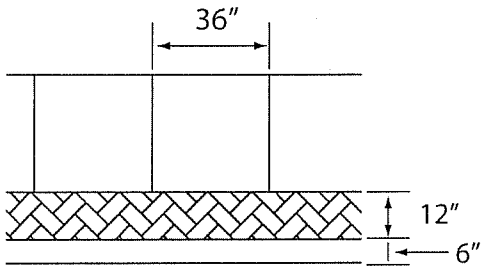

Figure 4

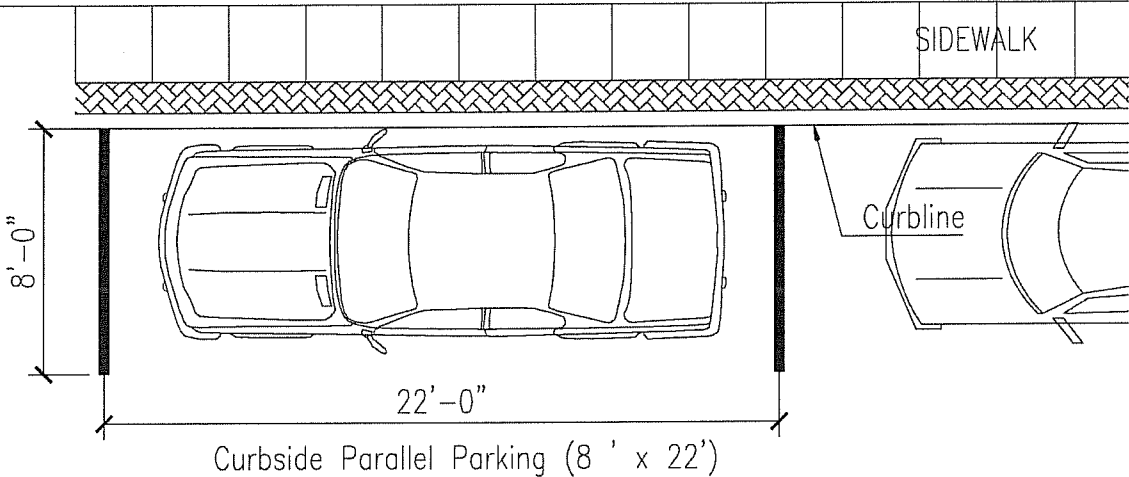

Figure 5

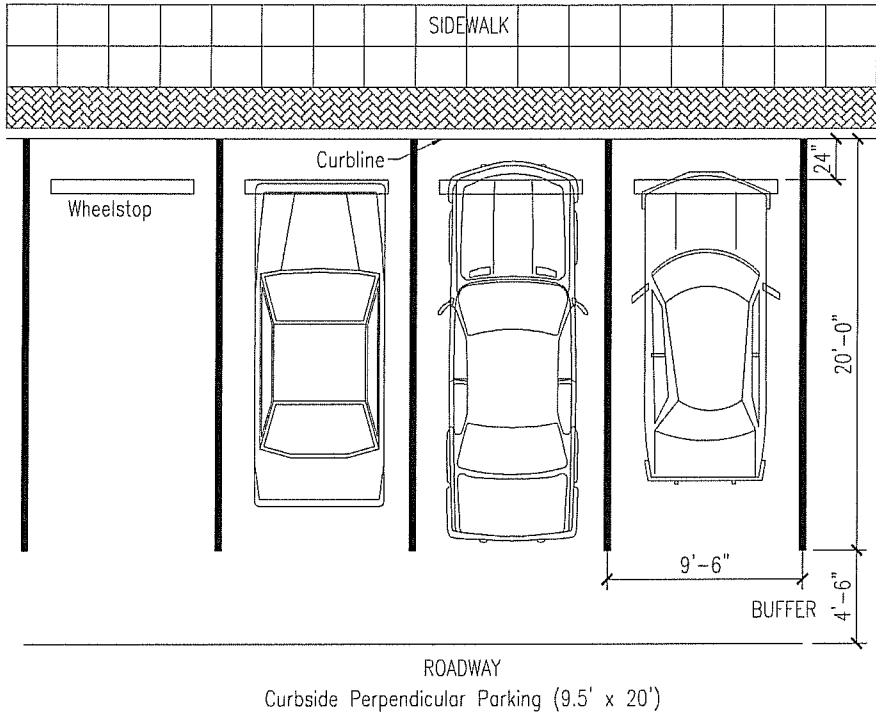

Figure 6

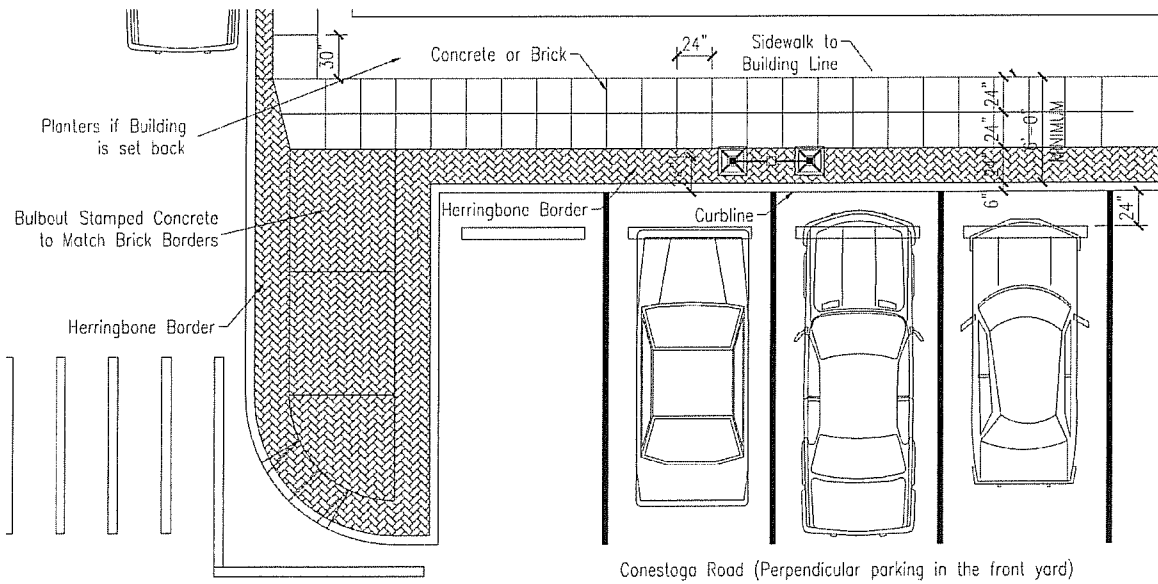

Figure 7

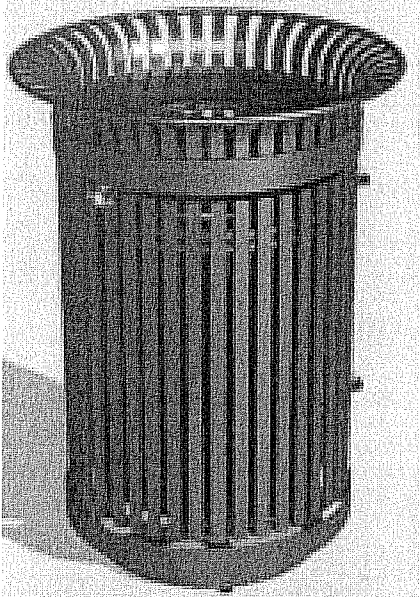

Figure 8

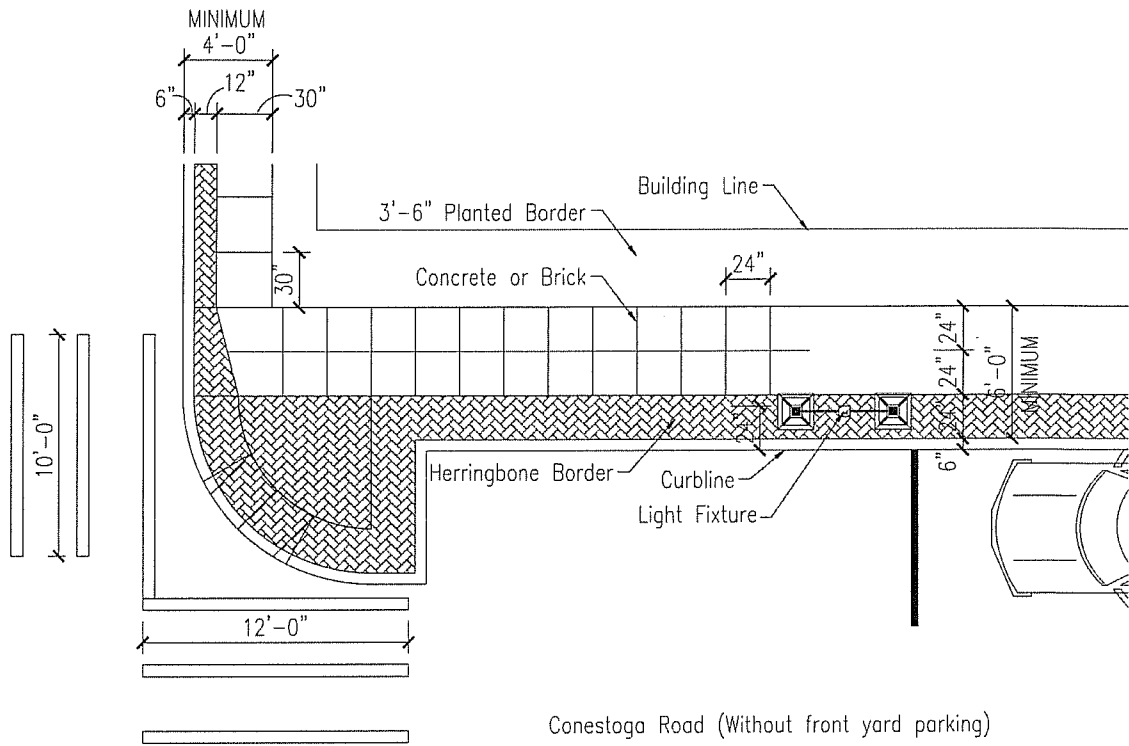
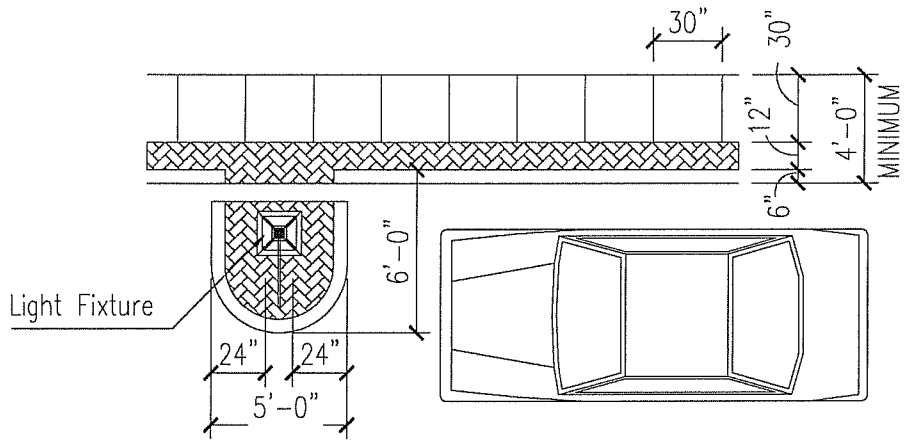

Figure 9



ON GARRETT AVENUE
 LIGHTS IN BULBOUTS
 ARE ENCOURAGED

